

Surrogate modeling using INR and uncertainty quantification

ANITI



ISAE
Institut Supérieur de l'Aéronautique et de l'Espace
SUPAERO

HALSED & PhySimAI

M. Bauerheim

Feb. 2026

Introduction

Main goal of this talk

*How to create an effective surrogate model for CFD applications using **deep network**?*

CFD = Computational Fluid Dynamics
= simulation of fluid flows

Introduction

Main goal of this talk

How to create an effective surrogate model for CFD applications using **deep network**?



Combustion in engines

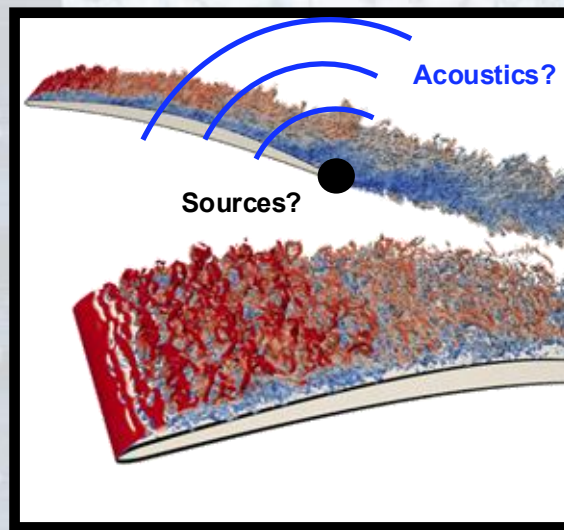

Aerodynamics and acoustics (e.g wing)

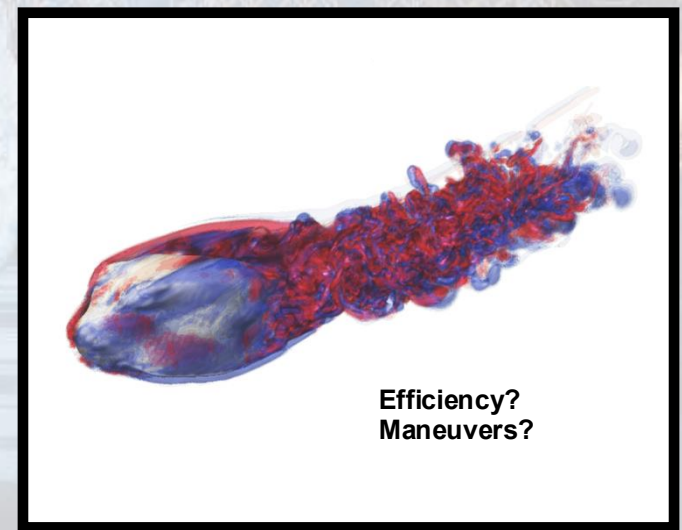

Bio-inspiration (e.g boxfish)

BUT fluid flows are challenging:

- ✓ Expensive to compute (10^3 - 10^7 CPUh)
 - ✓ Few data ($10^1 - 10^3$ samples)
- ✓ Unstructured data (mesh = very large graph)
 - ✓ Data is huge (10^7 - 10^9 degree of freedom)
 - ✓ Expensive to store (1-100 Go per data)
 - ✓ Nonlinear (e.g turbulence, shocks etc.)
 - ✓ Multi-scale (large/small $\sim Re^{3/4} \sim 10^3$ - 10^5)

Introduction

Main goal of this talk

*How to create an effective surrogate model for CFD applications using **deep network**?*

Deep Learning methods?

- Well adapted to **high dimensional spaces**
- **Non-linear & differentiable** by construction
- Can leverage **large (noisy) datasets**
- **Flexible method** (dynamical systems, videos, unstructured fields, point clouds, distributions, ...)

Introduction

Main goal of this talk

How to create an effective surrogate model for CFD applications using **deep network**?

Deep Learning methods?

- Well adapted to **high dimensional spaces**
- **Non-linear & differentiable** by construction
- Can leverage **large (noisy) datasets**
- **Flexible method** (dynamical systems, videos, unstructured fields, point clouds, distributions, ...)

Current difficulties?

- What about **limited dataset**?
 - Are they really **accurate** (e.g. on multi-scale problems)?
- } **Sample-Efficiency?**
Accuracy = f(dataset size)

Introduction

Main goal of this talk

How to create an effective surrogate model for CFD applications using **deep network**?

Deep Learning methods?

- Well adapted to **high dimensional spaces**
- **Non-linear & differentiable** by construction
- Can leverage **large (noisy) datasets**
- **Flexible method** (dynamical systems, videos, unstructured fields, point clouds, distributions, ...)

Current difficulties?

- What about **limited dataset**?
 - Are they really **accurate** (e.g. on multi-scale problems)?
 - Are they **physically consistent**?
 - Can we **trust them**?
- } Guarantees & Uncertainties?**
- ... among many other opened questions today!

Introduction

Main goal of this talk

How to create an effective surrogate model for CFD applications using **deep network**?

Deep Learning methods?

- Well adapted to **high dimensional spaces**
- **Non-linear & differentiable** by construction
- Can leverage **large (noisy) datasets**
- **Flexi**
distrib

int clouds,

So is AI really adapted to CFD?

Current diffi

- What about **limited dataset**?
 - Are they really **accurate** (e.g. on multi-scale problems)?
 - Are they **physically consistent**?
 - Can we **trust them**?
- } **Guarantees & Uncertainties?**
- ... among many other opened questions today!

Presentation outline

1. How can AI represent complex flows?

- *From CNN to Implicit Neural Representation (INR)*

2. Can AI move from flow prediction to flow discovery?

- *Introducing Active Learning and Uncertainties*

3. Research vision and perspectives

- *Hailed & PhiSimAI*

Presentation outline

1. How can AI represent complex flows?

- *From CNN to Implicit Neural Representation (INR)*

2. Can AI move from flow prediction to flow discovery?

- *Introducing Active Learning and Uncertainties*

3. Research vision and perspectives

- *Hailsed & PhiSimAI*

1. How can AI represent complex flows

*How to learn flow solutions on **meshes** & **manifolds**?*

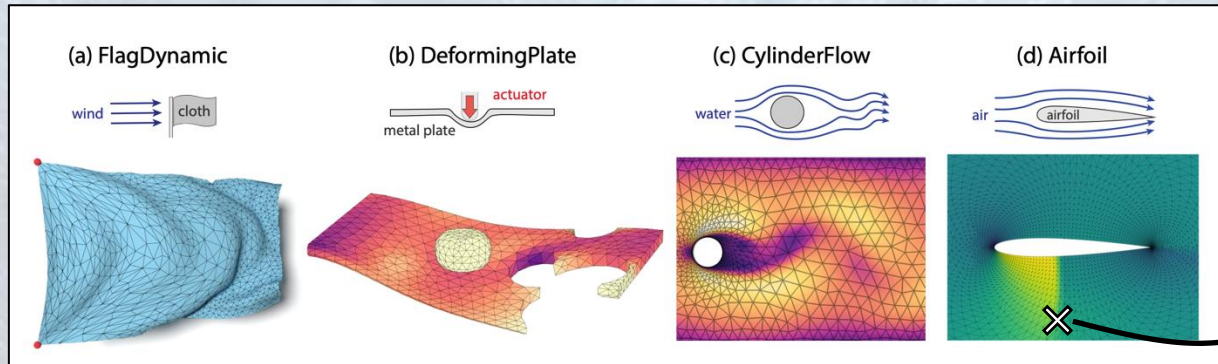

$N_{\text{node}} = 10^6 - 10^8$
Low connectivity
Long-distance interaction

Off-the-shelf AI models were NOT necessary well-adapted to CFD data format and requirements

1. How can AI represent complex flows

How to learn flow solutions on **meshes** & **manifolds**?

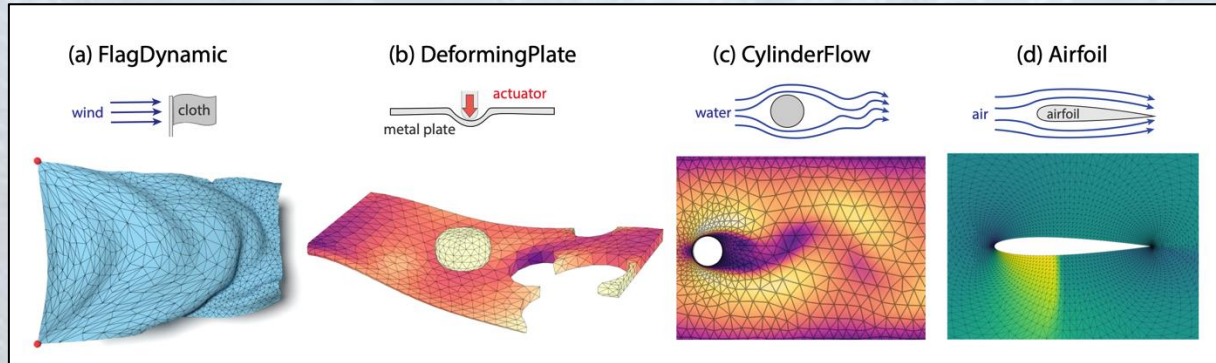

2017 - 2021

(a) Interpolation + Convolutional network

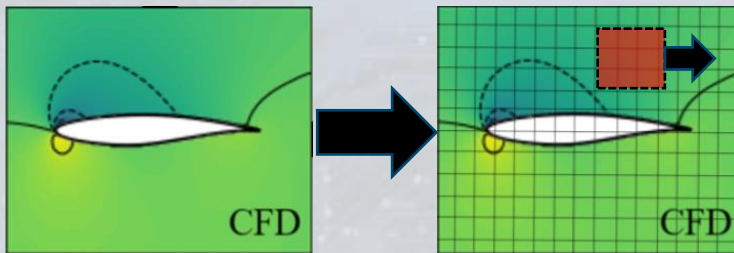

- Catalani et al., « A comparative study of learning techniques for the compressible aerodynamics over a RAE2822 airfoil », **Computers & Fluids**, 2023

1. How can AI represent complex flows

How to learn flow solutions on **meshes** & **manifolds**?

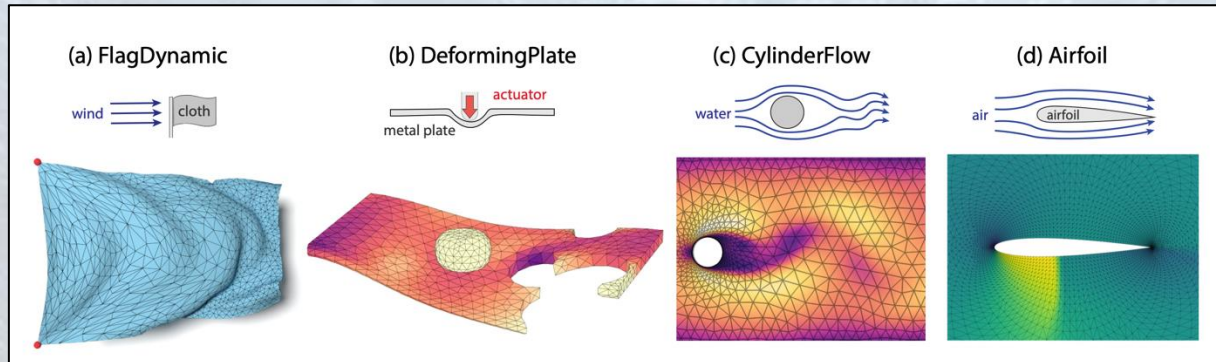

2017 - 2021

(a) Interpolation + Convolutional network

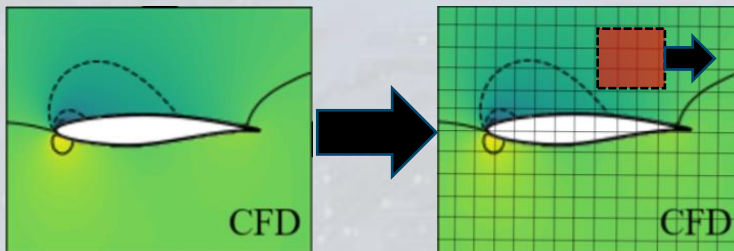

- ✓ Small (weight sharing)
- ✓ Easy to train
- ✓ Local in space (e.g Unet)
- ✗ Interpolation loss
- ✗ Resolution non-invariance

• Catalani et al., « A comparative study of learning techniques for the compressible aerodynamics over a RAE2822 airfoil », **Computers & Fluids**, 2023

1. How can AI represent complex flows

How to learn flow solutions on **meshes** & **manifolds**?

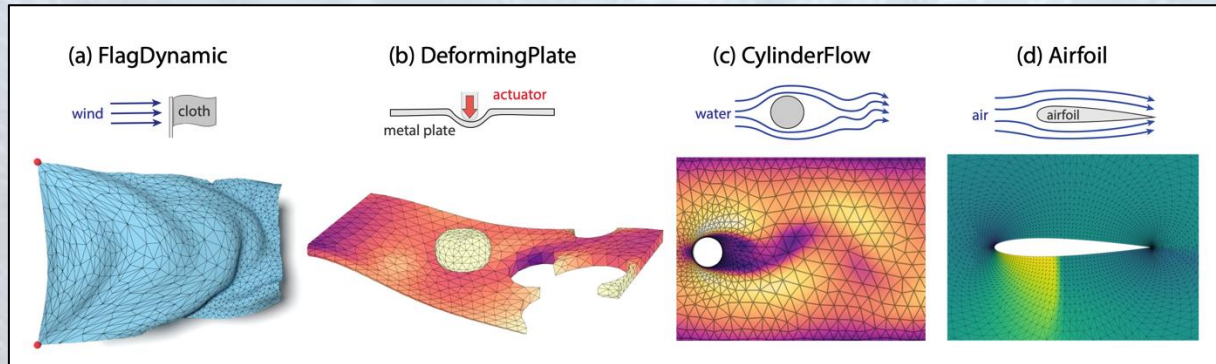

2017 - 2021

2021 – 20xx

(a) Interpolation + Convolutional network

(b) Graph Networks

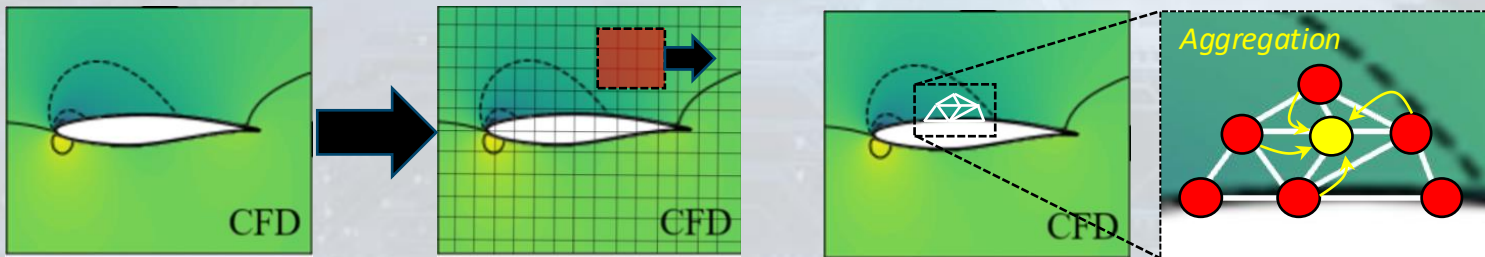

- Pfaf et al., « Learning mesh-based simulation with graph networks », ICLR, 2021

1. How can AI represent complex flows

How to learn flow solutions on **meshes** & **manifolds**?

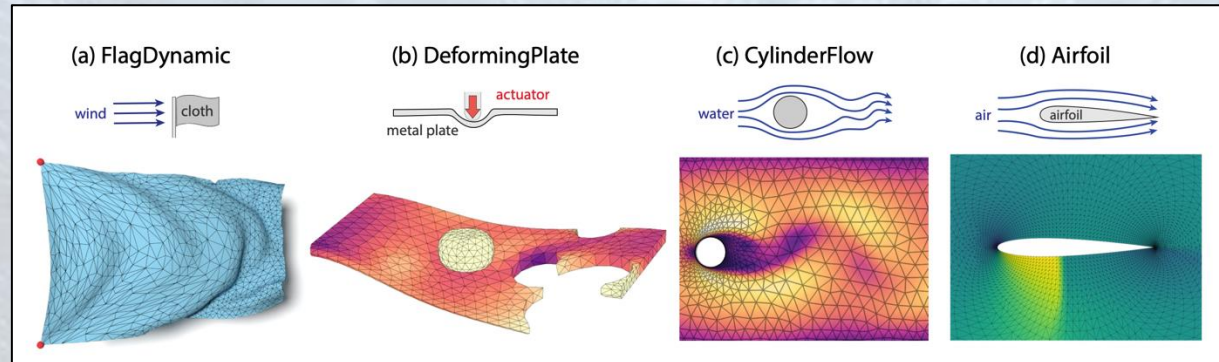

2017 - 2021

2021 – 20xx

- ✓ Adapted to meshes and CFD
- ✗ Resolution non-invariance
- ✗ Local in space
- ✗ Memory expensive

(b) Graph Networks

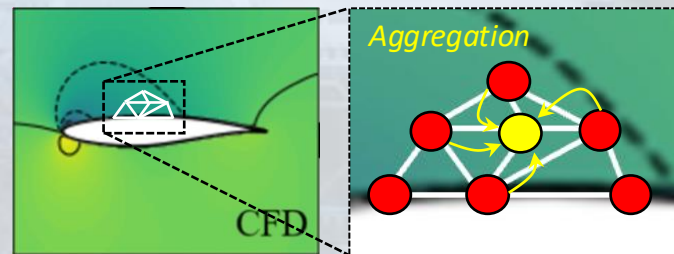

- Pfaf et al., « Learning mesh-based simulation with graph networks », ICLR, 2021

1. How can AI represent complex flows

How to learn flow solutions on **meshes** & **manifolds**?

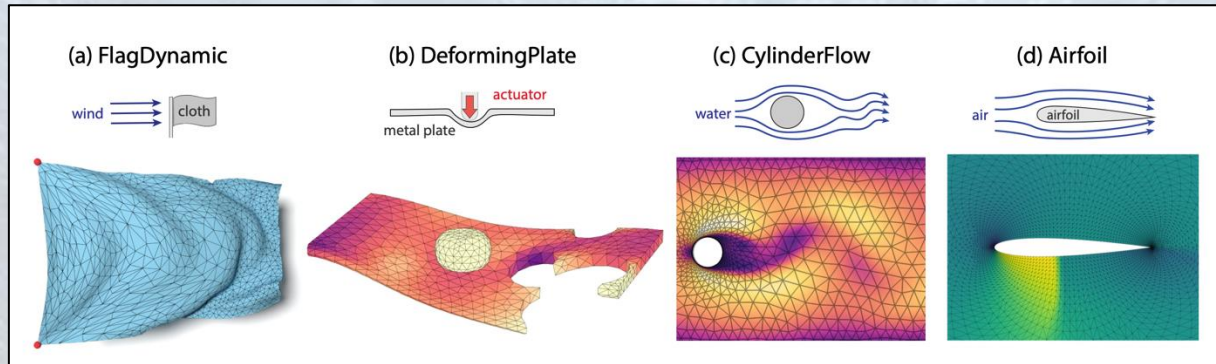

2017 - 2021

2021 - 20xx

2023 - 20xx

(a) Interpolation + Convolutional network

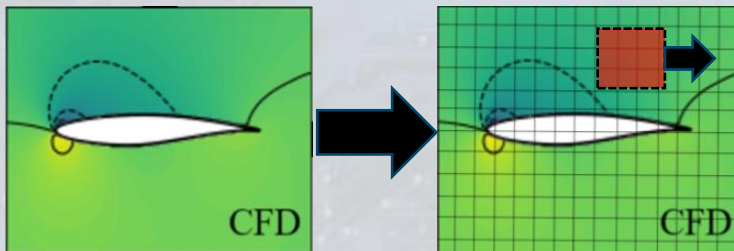

(b) Graph Networks

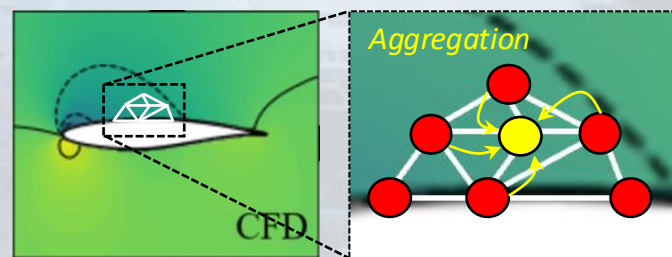

(c) MLP

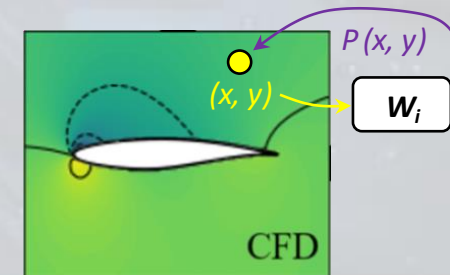

1. How can AI represent complex flows

How to learn flow solutions on **meshes** & **manifolds**?

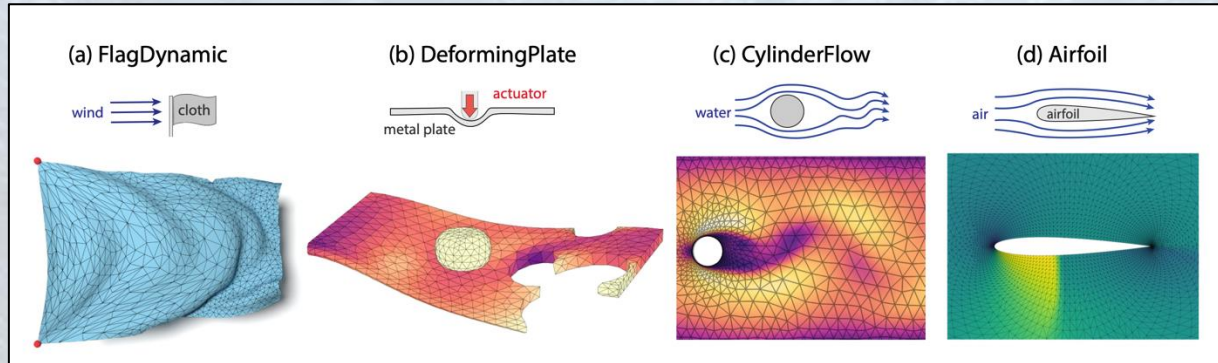

**Fourier features
(Tancik et al.)**



2017 - 2021

2021 - 20xx

2023 - 20xx

(a) Interpolation + Convolutional network

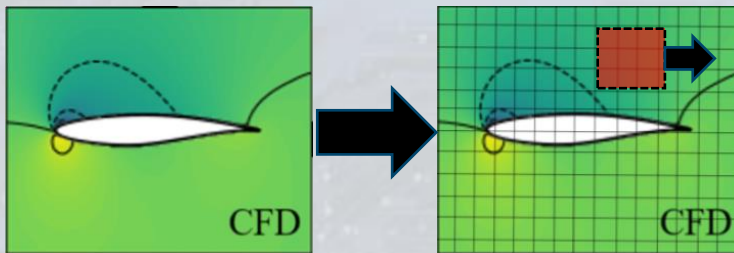

(b) Graph Networks

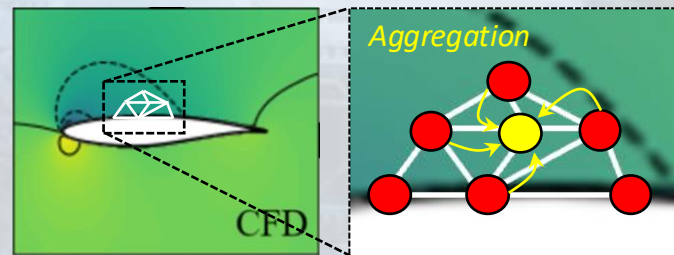

(c) Implicit Neural Representation (INR)

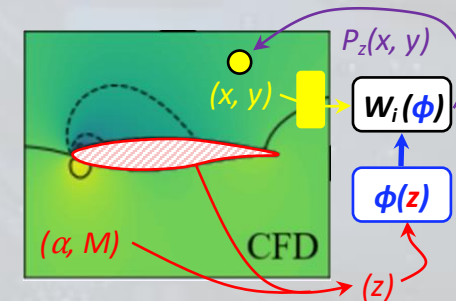

Modulation

- Tancik et al., « Fourier Features Let networks learn high frequency functions in low dimensional space », NeurIPS, 2020
- Catalani et al., « Neural fields for rapid aircraft aerodynamics simulations », **Scientific Report**, 2024

1. How can AI represent complex flows

How to learn flow solutions on **meshes** & **manifolds**?

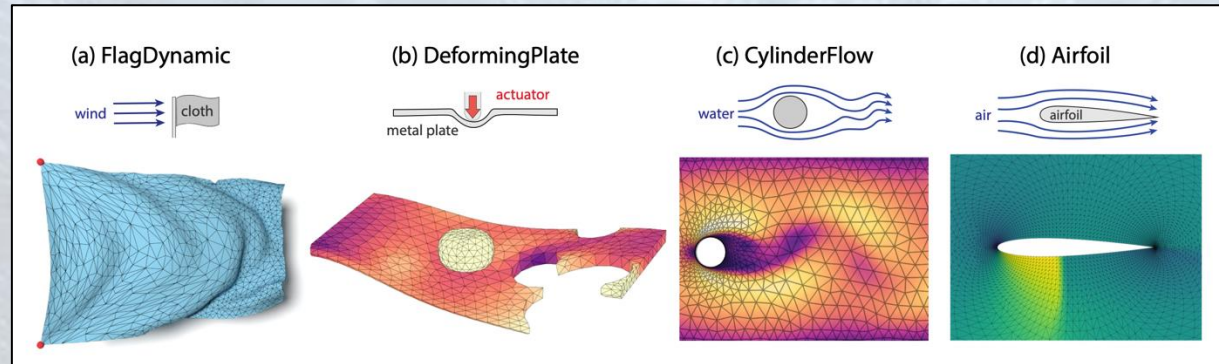

**Fourier features
(Tancik et al.)**



2017 - 2021

2021 - 20xx

2023 - 20xx

(a) Interp
Convolution

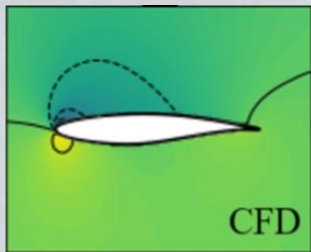

- ✓ Versatile
- ✓ Resolution invariance (continuous)
- ✓ Non-Local in space
- ✓ Memory efficient
- ✓ Easy and flexible to train
- ✗ Not yet fully mature

orks

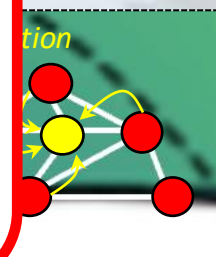

(c) Implicit Neural Representation (INR)

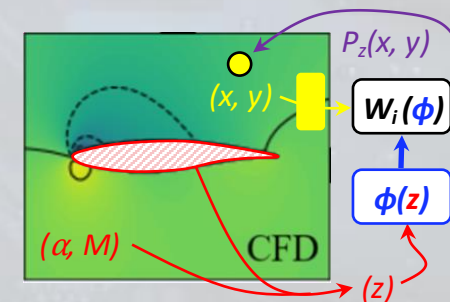

Modulation

- Tancik et al., « Fourier Features Let networks learn high frequency functions in low dimensional space », NeurIPS, 2020
- Catalani et al., « Neural fields for rapid aircraft aerodynamics simulations », Scientific Report, 2024

1. How can AI represent complex flows

- Fan blade – 3D varying geometries & Operating point (flow separation, shocks)
290 samples over varying shapes



DGEN-380 (Akira)

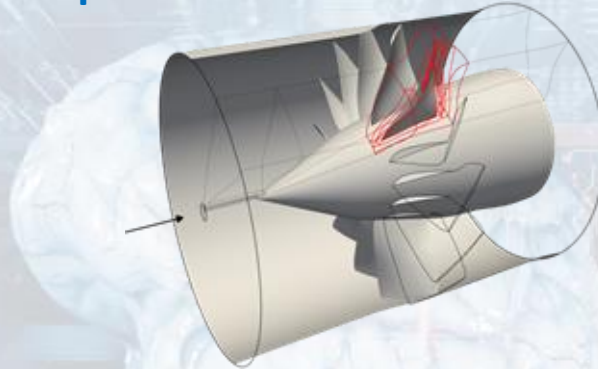

- *Single geometry [FaNN380]*
- *Various geometries [FaNN]*

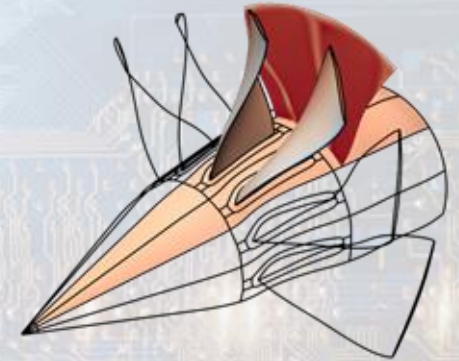

3D CFD dataset
[FaNN380 : 60 ; FaNN : 290]
Mesh : 10^7 nodes

1. How can AI represent complex flows

- Fan blade – 3D varying geometries & Operating point (flow separation, shocks)
290 samples over varying shapes



DGEN-380 (Akira)

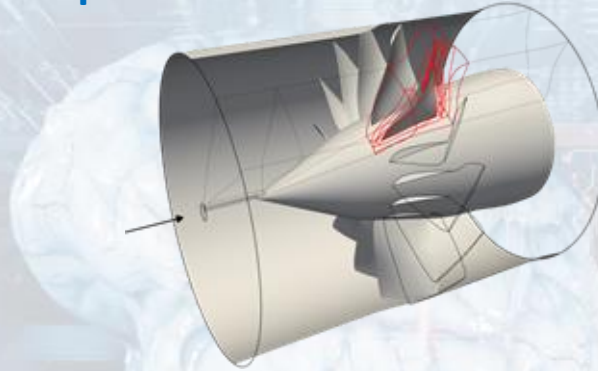

- Single geometry [FaNN380]
- Various geometries [FaNN]

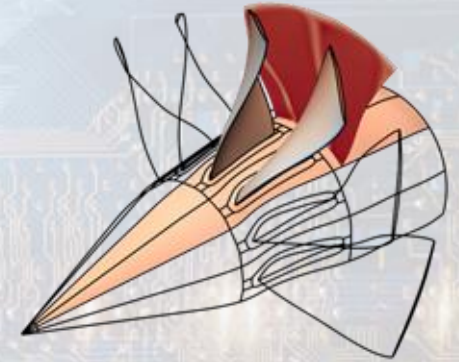

3D CFD dataset
[FaNN380 : 60 ; FaNN : 290]
Mesh : 10^7 nodes

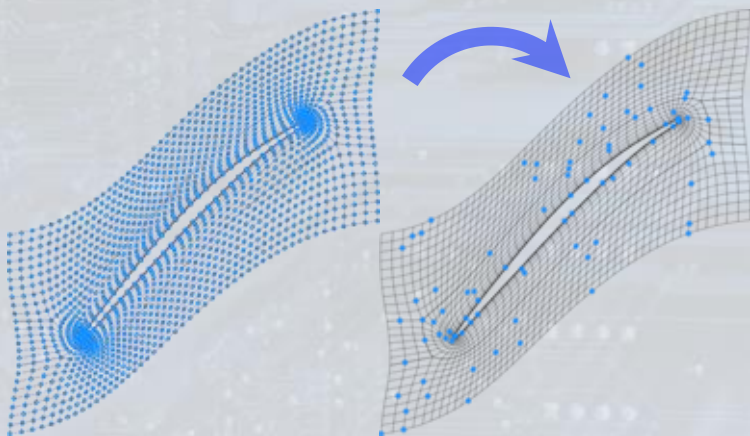

Mesh sampling for fast training

1. How can AI represent complex flows

- Fan blade – 3D varying geometries & Operating point (flow separation, shocks)
290 samples over varying shapes



DGEN-380 (Akira)

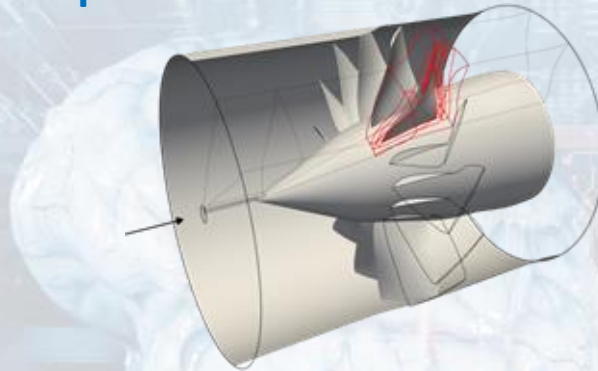

- Single geometry [FaNN380]
- Various geometries [FaNN]

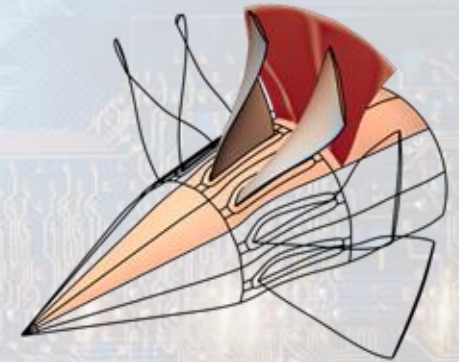

3D CFD dataset
[FaNN380 : 60 ; FaNN : 290]
Mesh : 10^7 nodes

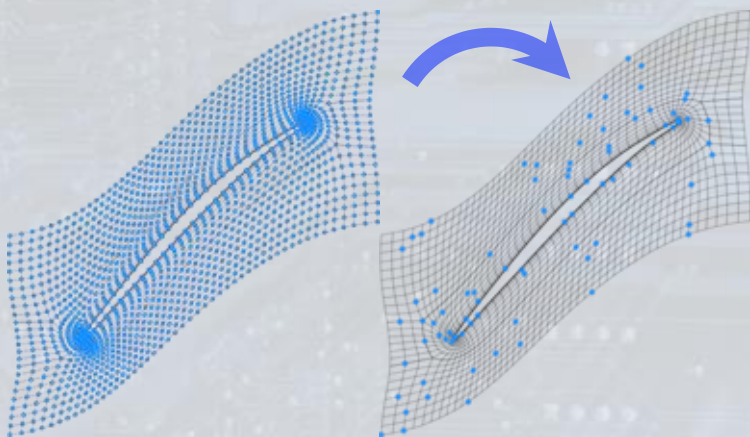

Mesh sampling for fast training

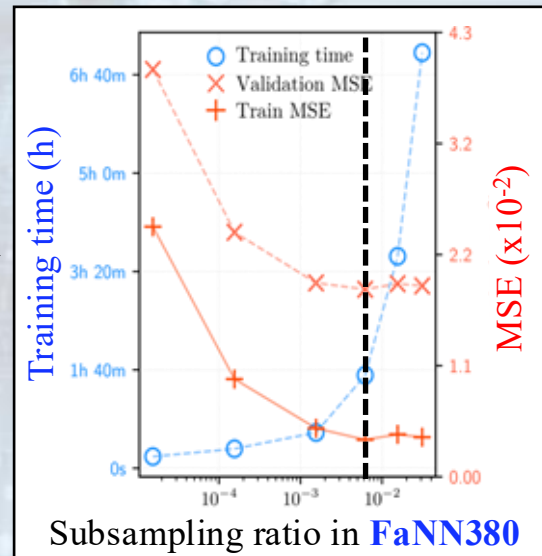

1. How can AI represent complex flows

- Fan blade – 3D varying geometries & Operating point (flow separation, shocks)
290 samples over varying shapes



DGEN-380 (Akira)

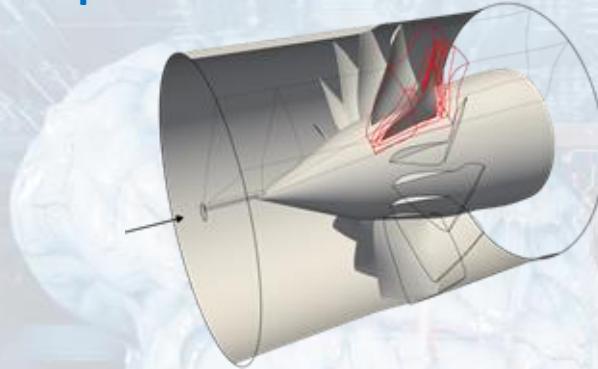

- Single geometry [FaNN380]
- Various geometries [FaNN]

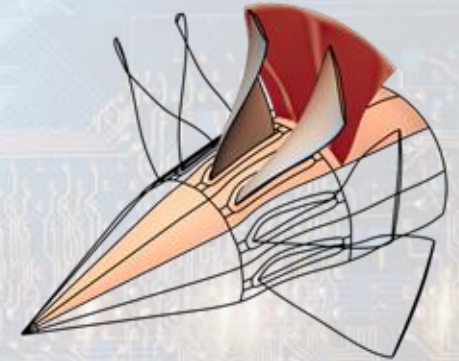

3D CFD dataset
[FaNN380 : 60 ; FaNN : 290]
Mesh : 10^7 nodes

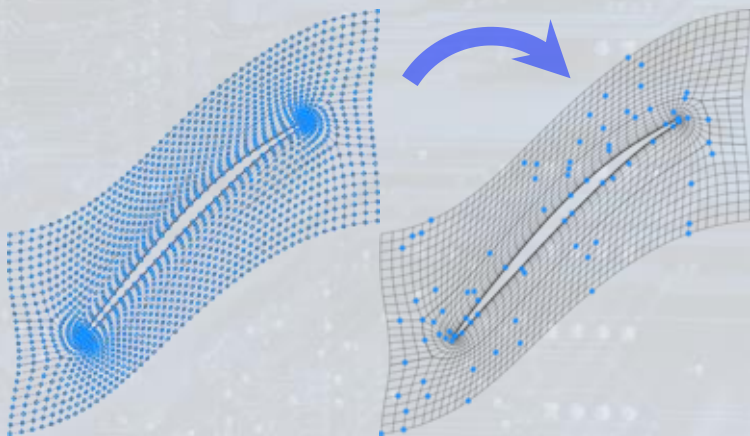

Mesh sampling for fast training

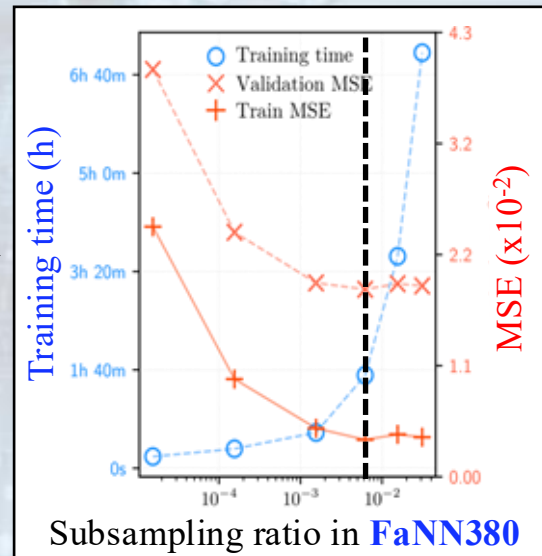

Case	Time	Samples
FaNN380	1h30	60
FaNN	8h	290

1. How can AI represent complex flows

- Fan blade – 3D varying geometries & Operating point (flow separation, shocks)
290 samples over varying shapes

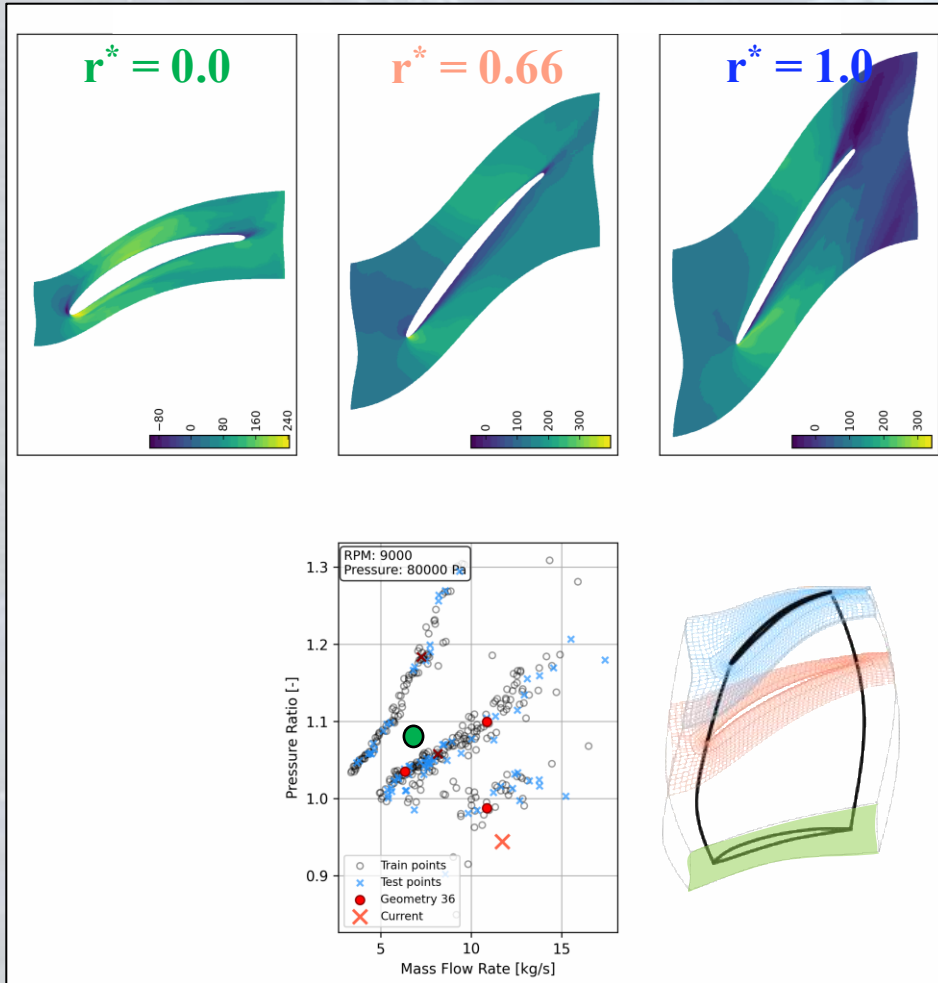

1. How can AI represent complex flows

- Fan blade – 3D varying geometries & Operating point (flow separation, shocks)
290 samples over varying shapes

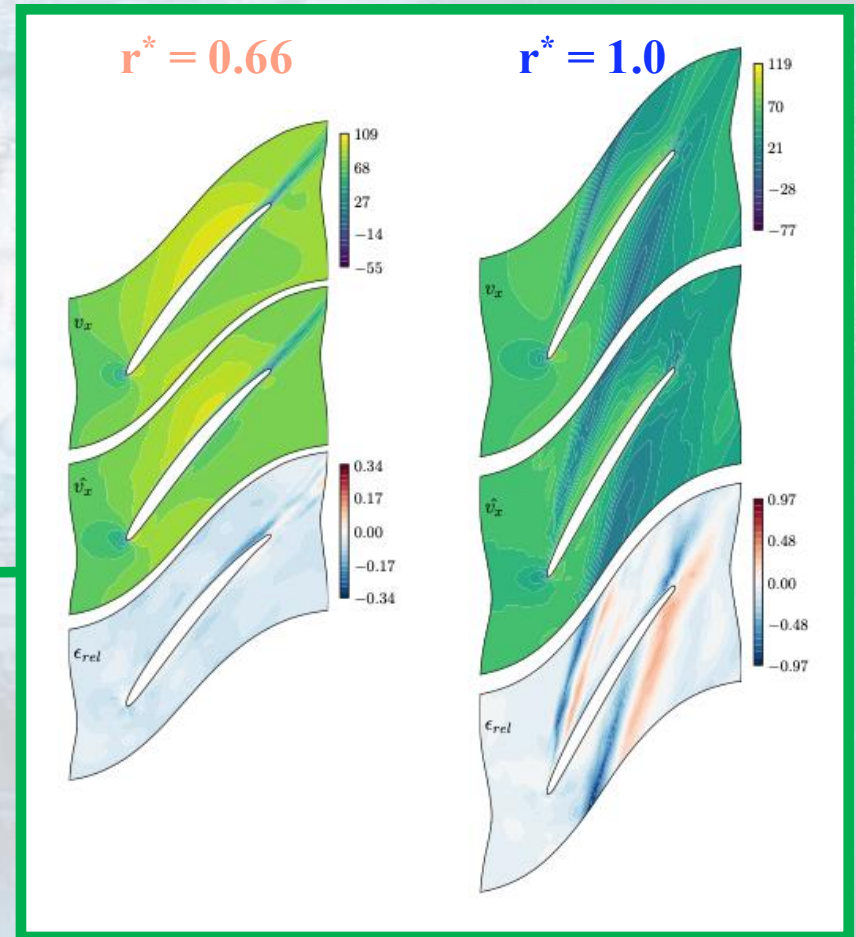
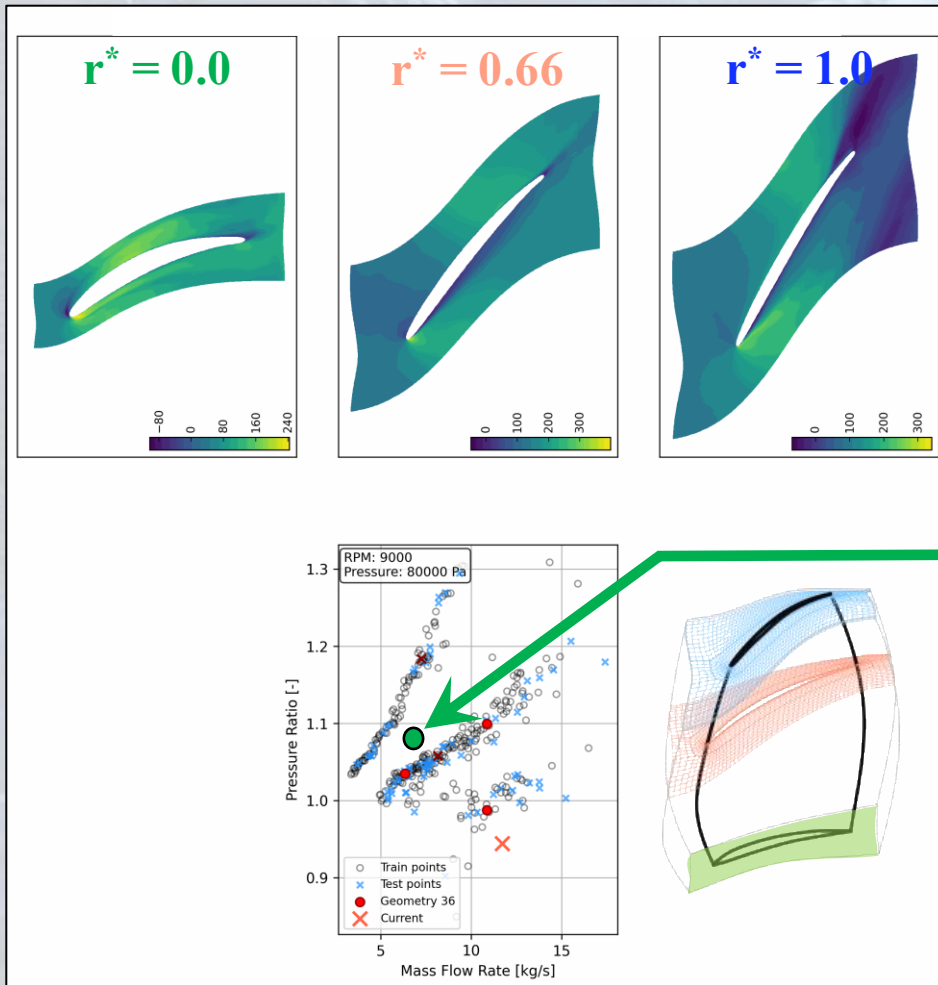

1. How can AI represent complex flows

- Fan blade – 3D varying geometries & Operating point (flow separation, shocks)
290 samples over varying shapes

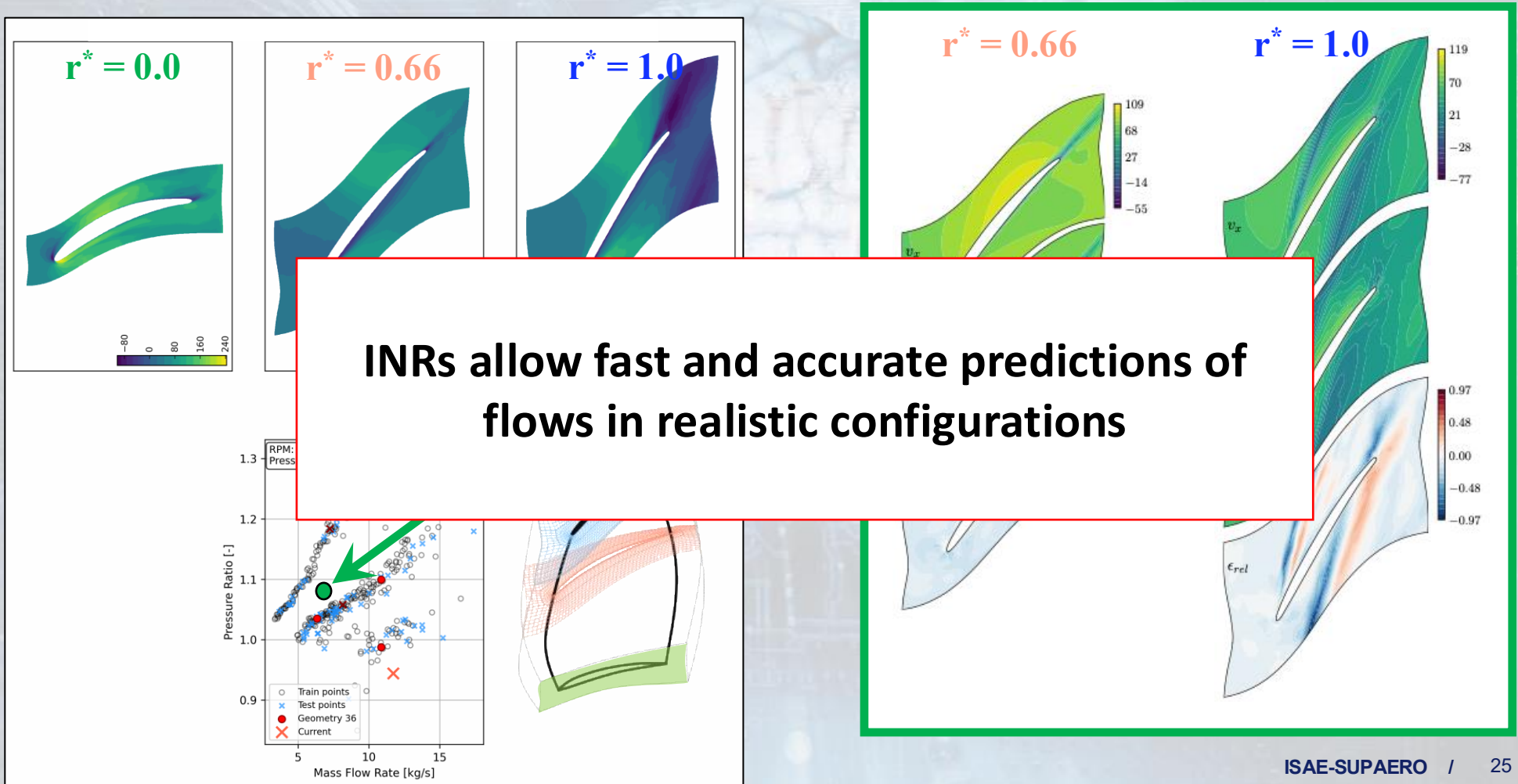

1. How can AI represent complex flows

*How to learn flow solutions on **meshes** & **manifolds**?*

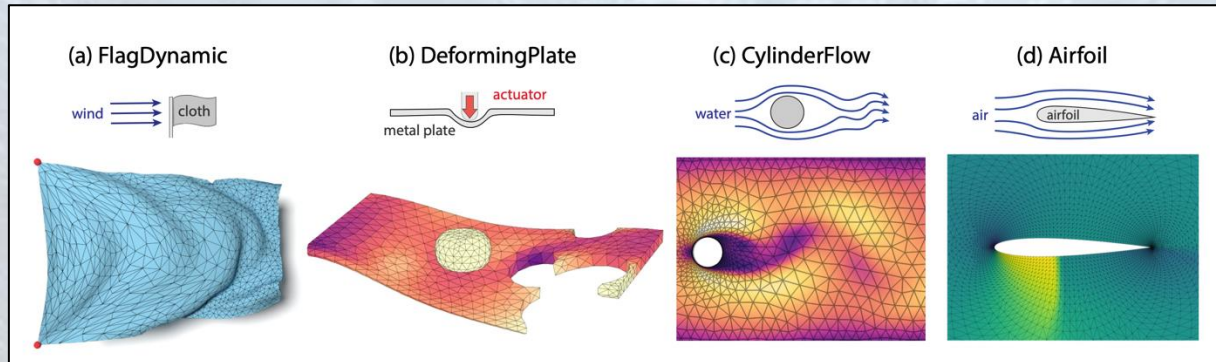

2017 - 2021

2021 – 20xx

2023 – 20xx

2026?

What would be the next generation of AI models?

- **Attention-based models?** e.g. AROMA, ENMA, Equivariant Neural Fields
- **Foundational models?** e.g. FluidZero
- **Novel physics-based AI methodology?** e.g. GLOBE

- A. Kassaï Koupaï et al., « ENMA: tokenwise autoregression for generative Neural PDE operators », **NeurIPS**, 2025
- L. Serrano et al. « AROMA: preserving spatial structure for latent PDE modeling with local neural fields », **NeurIPS**, 2024
- G. Catalani et al., « Geometry aware inference of steady state PDEs using equivariant neural field representations », **NeurIPS workshop**, 2025
- H. Feng et al., « FluidZero: mastering diverse tasks in fluid systems through a single generative model », **not peer reviewed**, 2025
- P. Sharp, « GLOBE: accurate and generalizable PDE surrogates using domain-inspired architectures and equivariance », **arXiv**, 2025

Presentation outline

1. *How can AI represent complex flows?*

- *From CNN to Implicit Neural Representation (INR)*

2. *Can AI move from flow prediction to flow discovery?*

- *Introducing Active Learning and Uncertainties*

3. *Research vision and perspectives*

- *Hailsed & PhiSimAI*

2. Can AI move from prediction to discovery?



Honeybee flapping motion

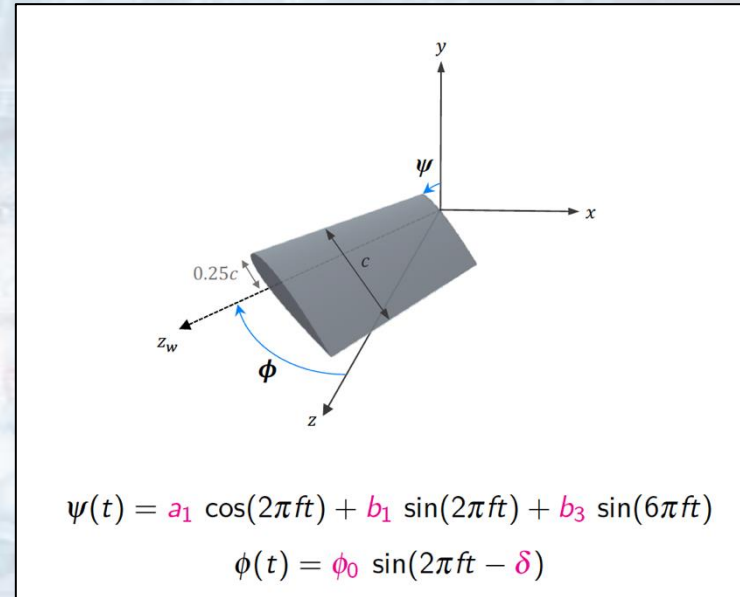

5D Parameterization of the kinematics for DNS

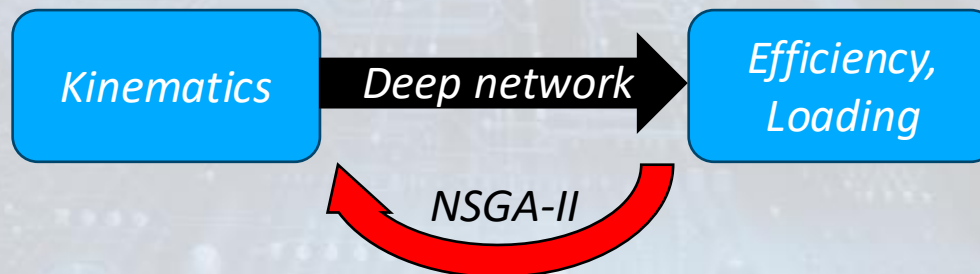

2. Can AI move from prediction to discovery?

Optimisation using DL yields a pareto front

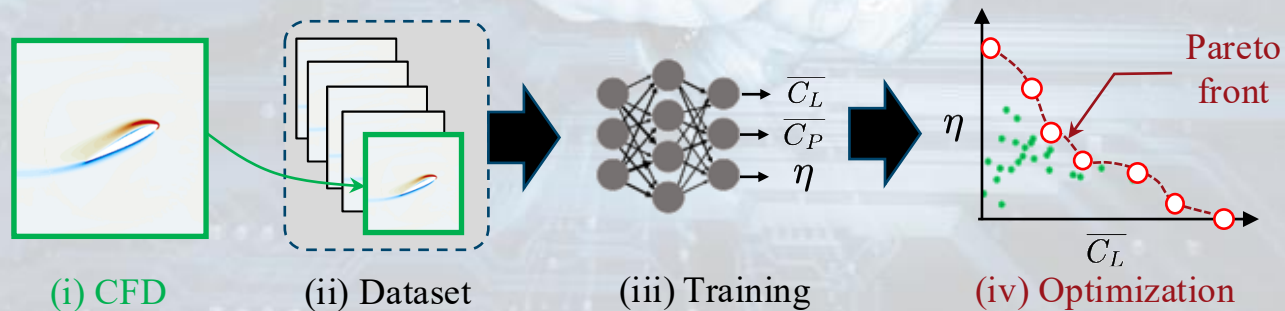
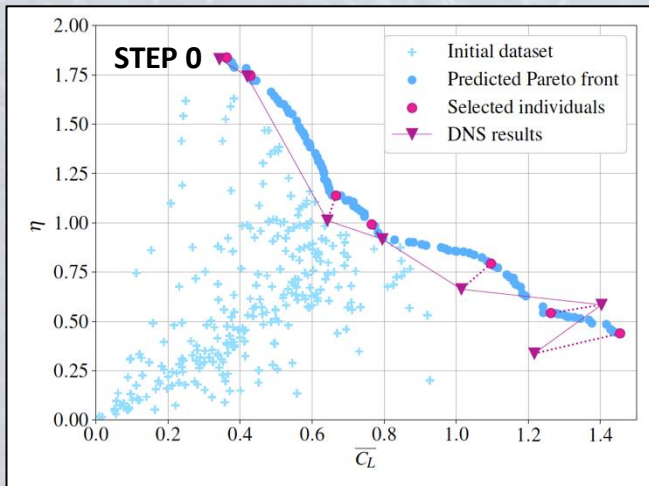

2. Can AI move from prediction to discovery?

DL is **unreliable**: iterative process (**active learning**)

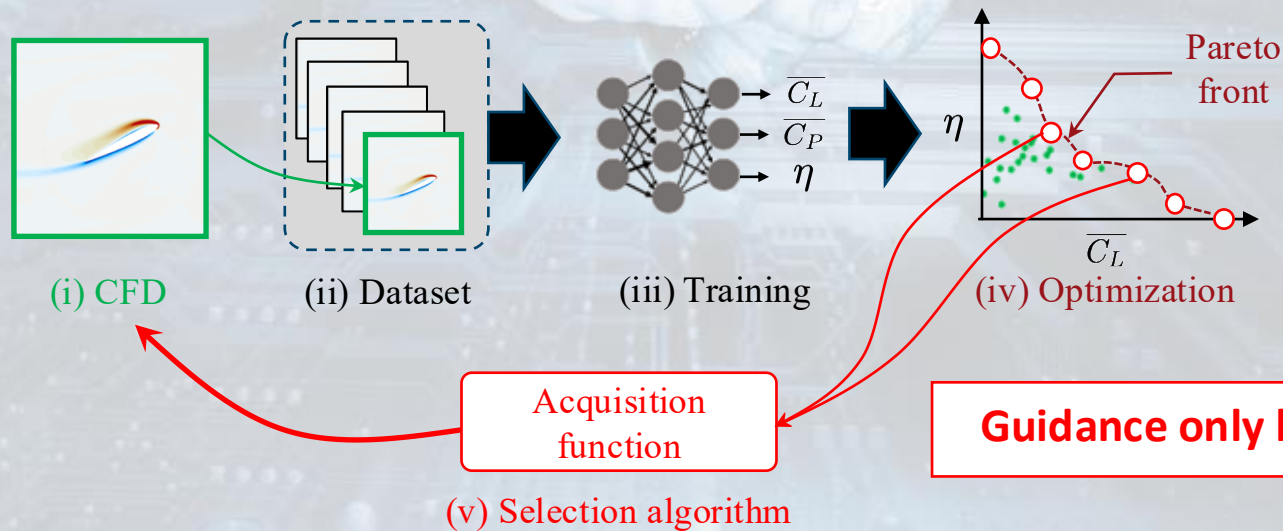
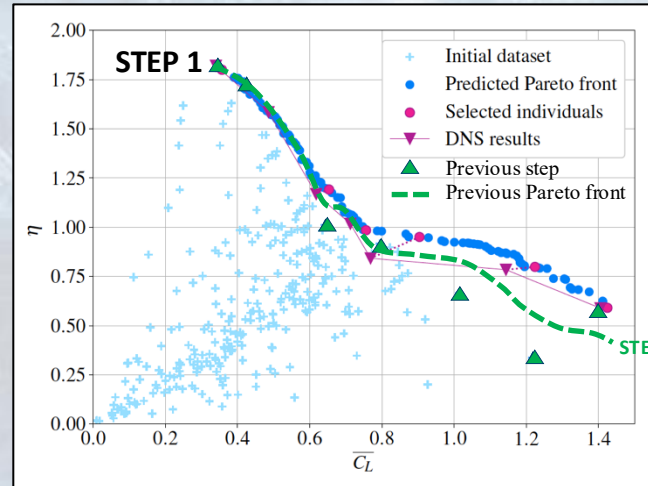
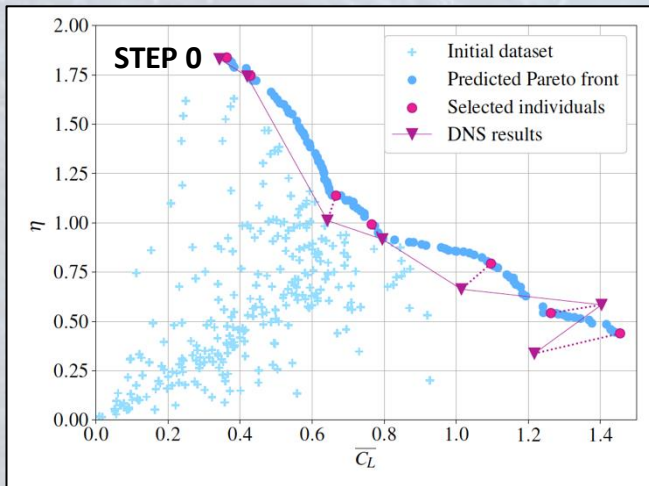

2. Can AI move from prediction to discovery?

DL is **unreliable**: iterative process (**active learning**)

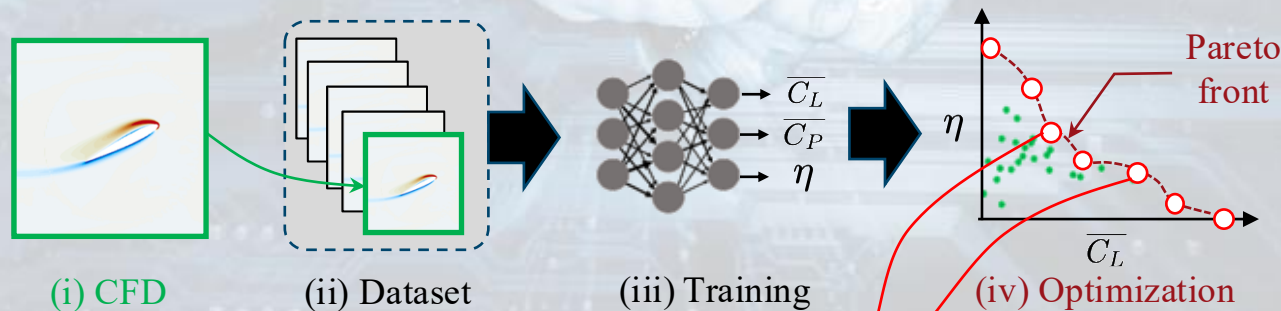
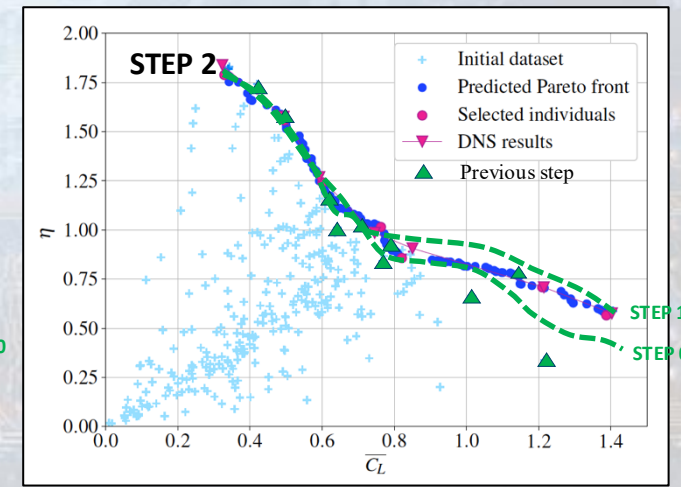
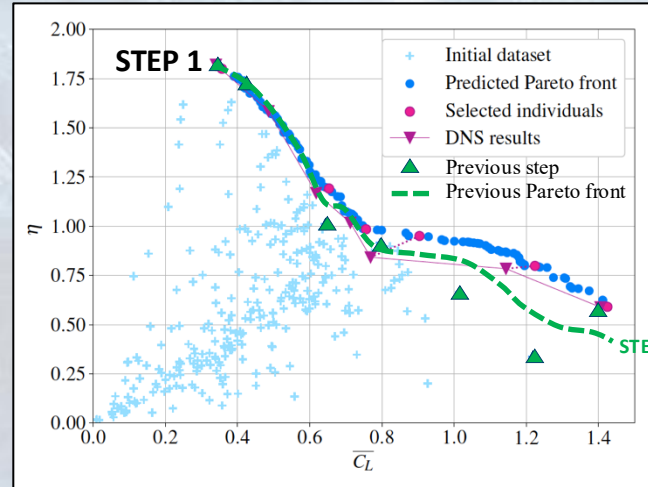
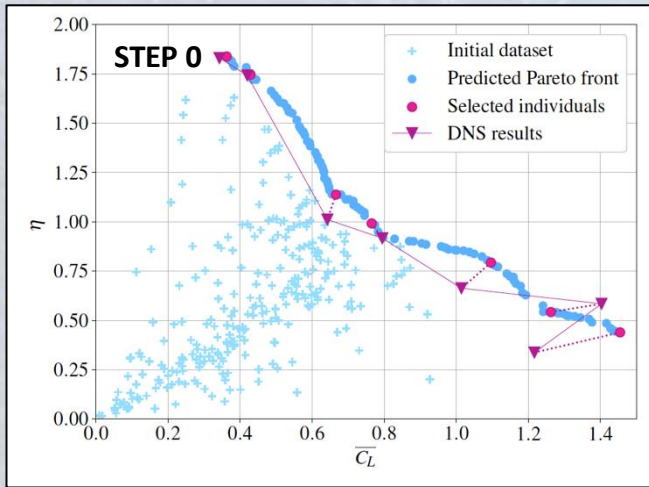

Acquisition function

Guidance only by errors

(v) Selection algorithm

2. Can AI move from prediction to discovery?

DL is **unreliable**: iterative process (**active learning**)

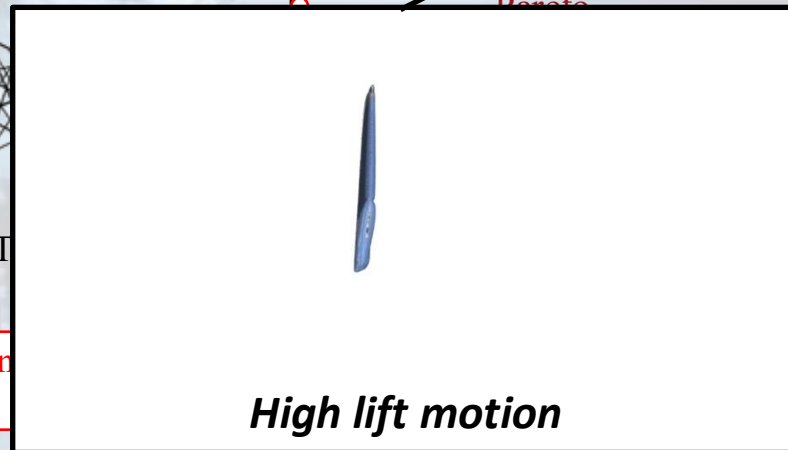
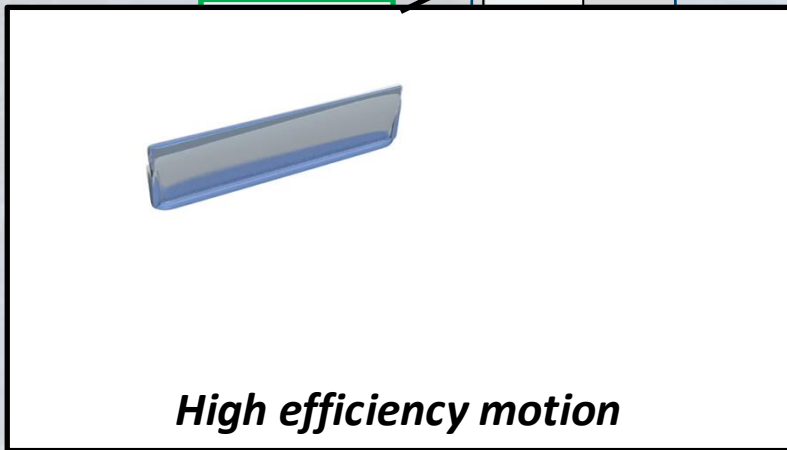
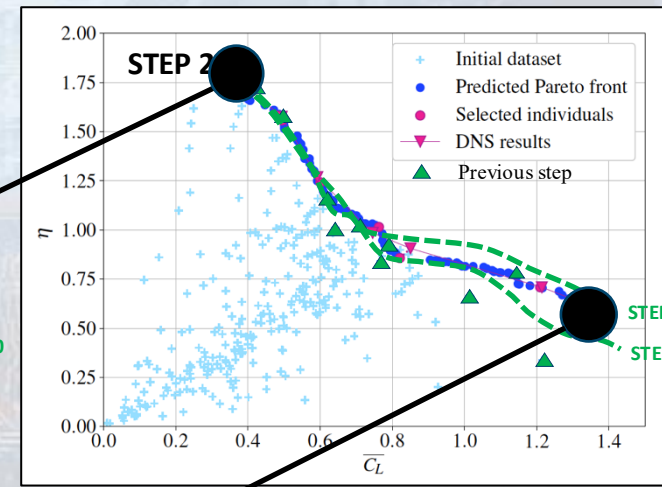
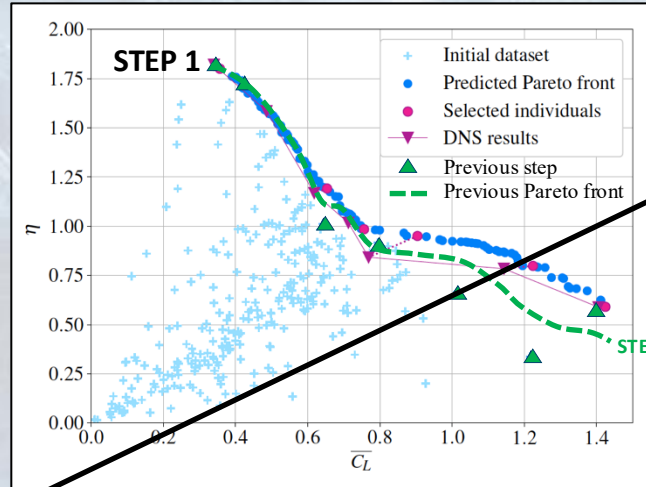
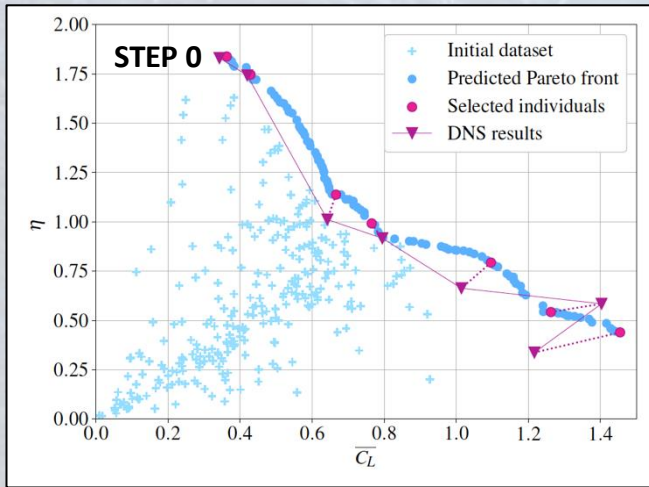

(v) Selection algorithm

2. Can AI move from prediction to discovery?

DL is **unreliable**: iterative process (**active learning**)

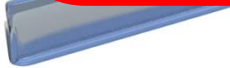
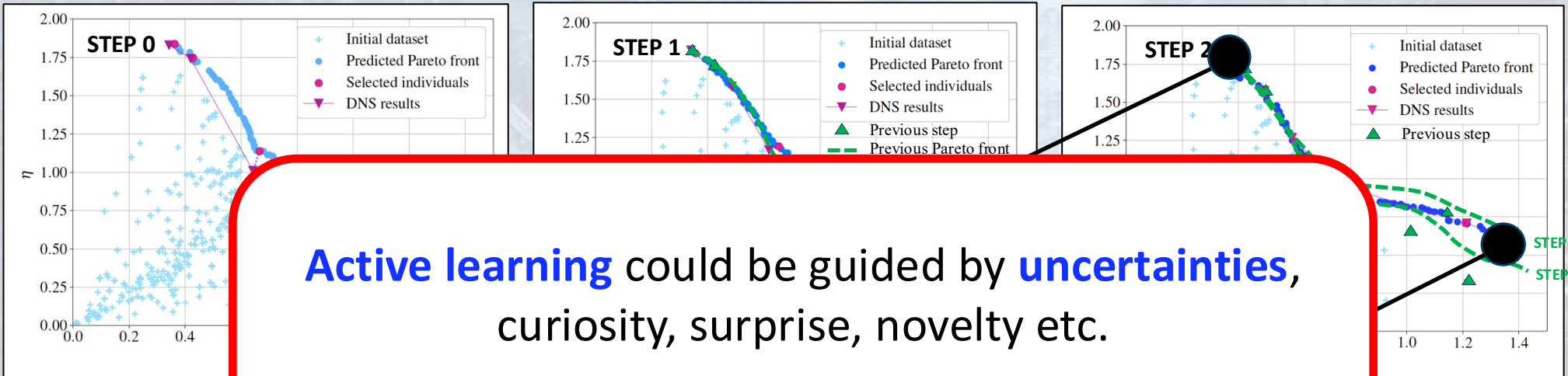

High efficiency motion

(iii) T

Position
action



High lift motion

(v) Selection algorithm

2. Can AI move from prediction to discovery?

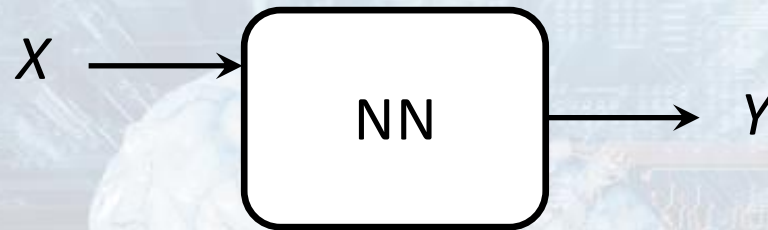

- Deep Ensemble (DE): *multiple uncorrelated* NN: uncertainties as *variance of the models* output

N trainings / N inferences

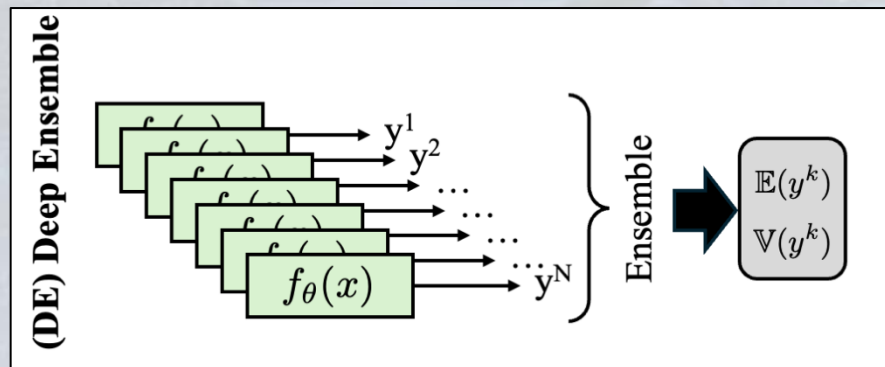

- Lakshminarayanan et al., « Simple and scalable predictive uncertainty estimation using DE », NIPS, 2017

2. Can AI move from prediction to discovery?

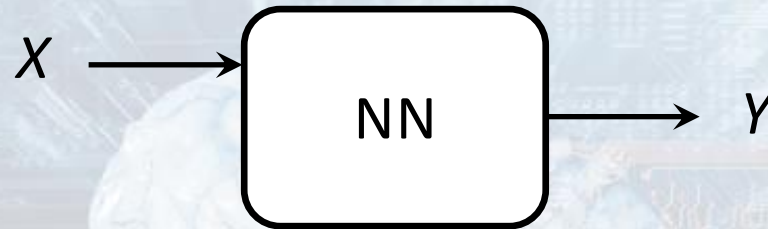

- Deep Ensemble (DE): **multiple uncorrelated** NN: uncertainties as **variance of the models** output
- MC Dropout (DO): **multiple correlated** NN: uncertainties as **variance of the models** output

N trainings / N inferences

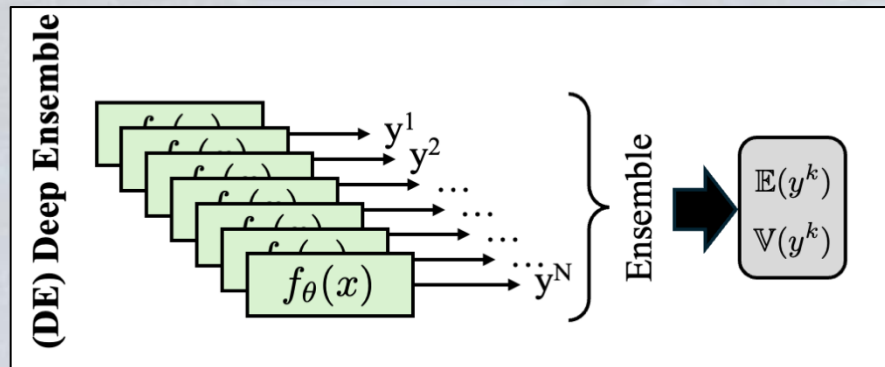

1 trainings / N inferences

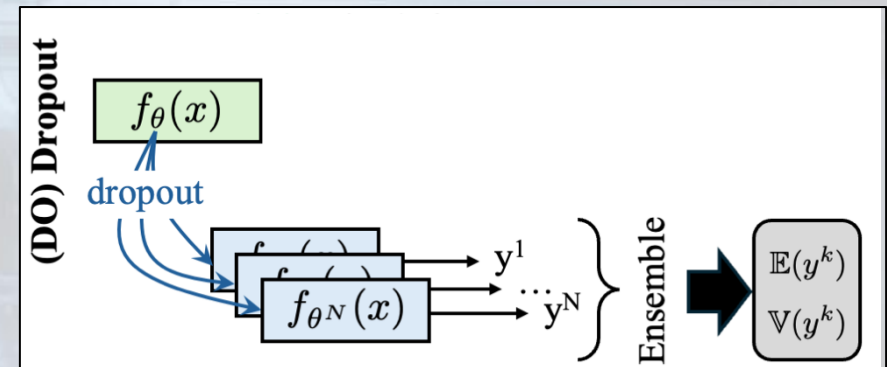

- Lakshminarayanan et al., « Simple and scalable predictive uncertainty estimation using DE », NIPS, 2017
- Gal et al., « Dropout as a Bayesian approximation », ICML, 2016

2. Can AI move from prediction to discovery?

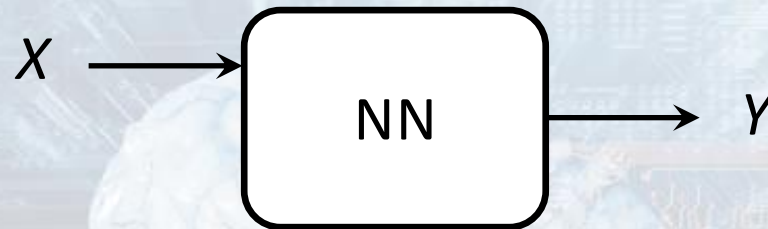

- Deep Ensemble (DE): *multiple uncorrelated* NN: uncertainties as *variance of the models* output
- MC Dropout (DO): *multiple correlated* NN: uncertainties as *variance of the models* output

	« Accuracy »	Cost
DE	Very good	Costly
MCD	So-so	Cheap

- Lakshminarayanan et al., « *Simple and scalable predictive uncertainty estimation using DE* », NIPS, 2017
- Gal et al., « *Dropout as a Bayesian approximation* », ICML, 2016

2. Can AI move from prediction to discovery?

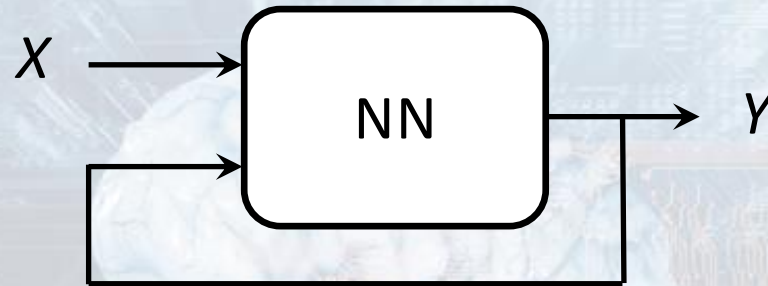

- ZigZag [Durasov et al.]: **single** model, but **run twice!**

□ Start from $\{X, Y=0\}$ – predict $Y^1 = NN(X, 0)$ – predict $Y^2 = NN(x, NN(x, 0))$

1 trainings / 2 inferences

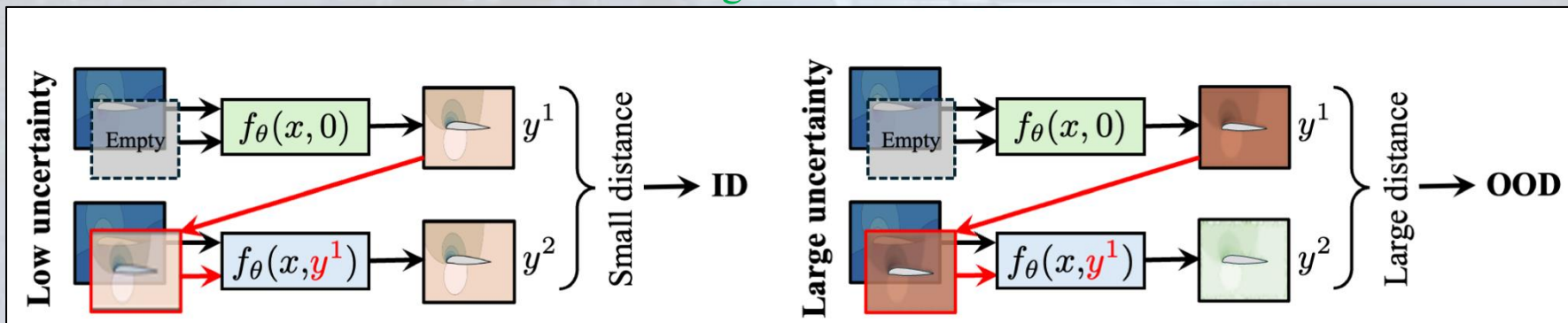

- Durasov et al., « ZigZag: universal sampling-free uncertainty estimation through 2-step inference », ICML, 2024

2. Can AI move from prediction to discovery?

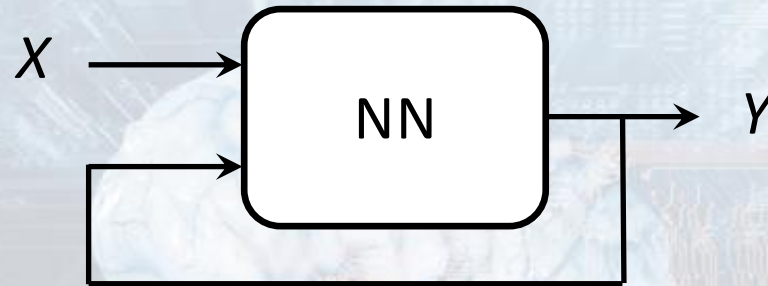

- ZigZag [Durasov et al.]: **single** model, but **run twice!**
 - ❑ Start from $\{X, Y=0\}$ – predict $Y^1 = NN(X, 0)$ – predict $Y^2 = NN(x, NN(x, 0))$
 - ❑ $|Y^1 - Y^2|$ is a measure of the **total uncertainty** [Foglia et al.]

2. Can AI move from prediction to discovery?

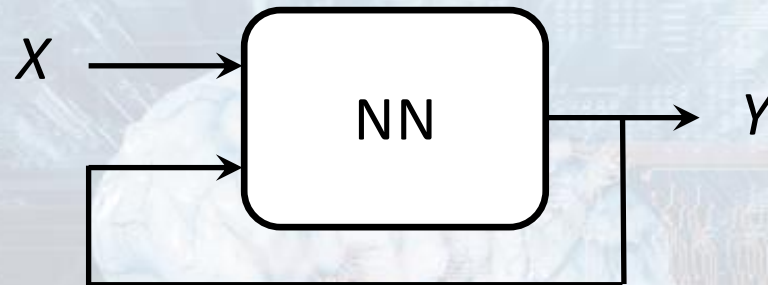

- ZigZag [Durasov et al.]: **single** model, but **run twice!**
 - ❑ Start from $\{X, Y=0\}$ – predict $Y^1 = NN(X, 0)$ – predict $Y^2 = NN(x, NN(x, 0))$
 - ❑ $|Y^1 - Y^2|$ is a measure of the **total uncertainty** [Foglia et al.]
- [Foglia et al.]: If you have **uncorrelated training pairs** $\{X, Y_1, Y_2\}$, then ZigZag can separate **aleatoric** vs. **Epistemic** uncertainties

$$Epistemic = Cov(\hat{Y}_1, \hat{Y}_2)$$

2. Can AI move from prediction to discovery?

- **Experimental tests**

Setup

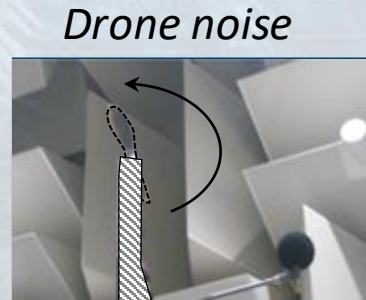

Outputs

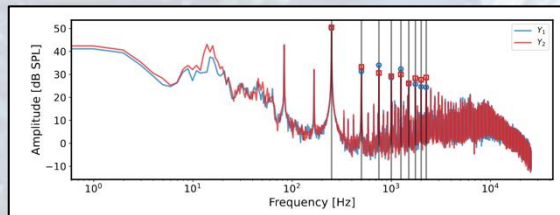

Noise spectrum

2. Can AI move from prediction to discovery?

- Experimental tests

Setup

Drone noise

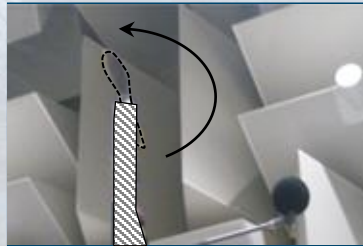

Airfoil aerodynamics

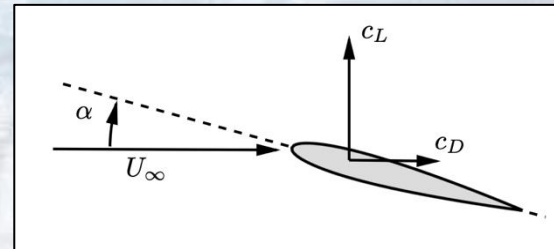

Outputs

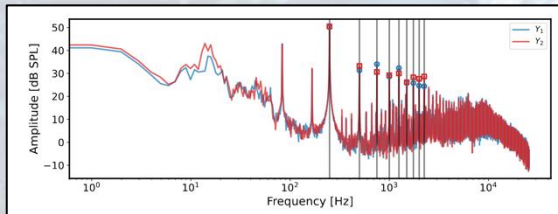

Noise spectrum

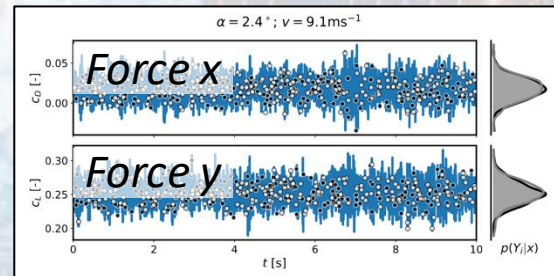

Aerodynamic forces

2. Can AI move from prediction to discovery?

- Experimental tests

Setup

Drone noise

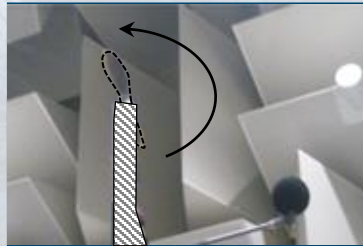

Airfoil aerodynamics

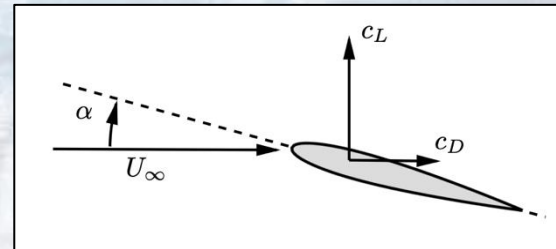

Outputs

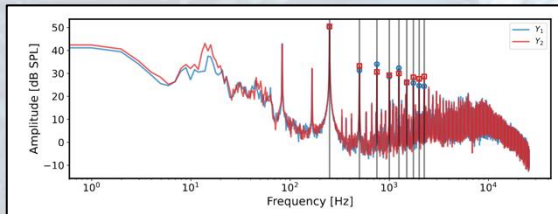

Noise spectrum

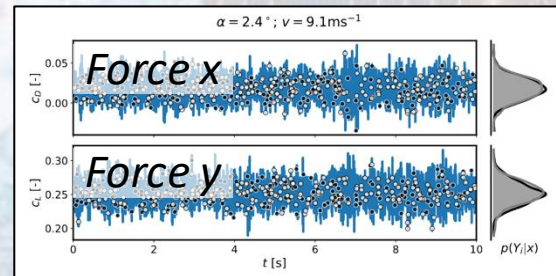

Results

Model	AUROC		Cost of training
	Drone noise	Airfoil aerodynamics	
Deep Ensembles	0.99±0.01	0.98±0.01	×5
MC Dropout	0.84±0.01	0.49±0.01	×1
Ours	0.88±0.03	0.87±0.02	×1.25

2. Can AI move from prediction to discovery?

- Experimental tests



Outputs

Next step is to **guide active learning using uncertainty** measures in INR-like architectures (on going work)

Results

Model	AUROC		Cost of training
	Drone noise	Airfoil aerodynamics	
Deep Ensembles	0.99±0.01	0.98±0.01	×5
MC Dropout	0.84±0.01	0.49±0.01	×1
Ours	0.88±0.03	0.87±0.02	×1.25

Presentation outline

1. *How can AI represent complex flows?*

- *From CNN to Implicit Neural Representation (INR)*

2. *Can AI move from flow prediction to flow discovery?*

- *Introducing Active Learning and Uncertainties*

3. *Research vision and perspectives*

- *Hailed & PhiSimAI*

3. Research vision and perspectives

AI in CFD is still new! Need to further improve methodologies tailored to its specific challenges



3. Research vision and perspectives

AI in CFD is still new! Need to further improve methodologies tailored to its specific challenges

HAILSED - Hybridizing AI with Large-scale Simulations for Engineering Design

(lead by A. Kopanicakova)

- Improve guarantees by **embedding AI into simulation** approaches
-

3. Research vision and perspectives

AI in CFD is still new! Need to further improve methodologies tailored to its specific challenges

HAISED - Hybridizing AI with Large-scale Simulations for Engineering Design

(lead by A. Kopanicakova)

- Improve guarantees by **embedding AI into simulation** approaches
-

Integrative program – PhySimAI

(lead by P. Novello)

- Create an **open-source toolbox** with state-of-the-art models **tailored to the specific challenges** of large engineering problems
- Develop **hybrid** and **uncertainty** approaches towards **trustworthy models**
- Benchmarks this on **realistic industrial** « demonstrators »

Conclusion

*Actually, we are still
far from replacing CFD*

*If I had feelings,
I would be very
disappointed*

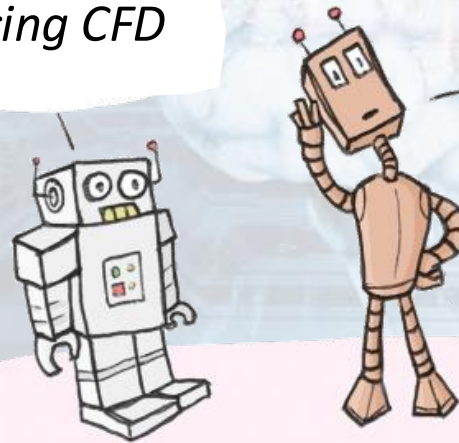

@vismktg
pour @sparklane_fr

Thank you!